



SAMPLE APPROVAL SHEET

Company Name _____

Part Number 921NIRPC/D28-S

Sample Date _____

APPROVED SIGNATURES		

APPROVED SIGNATURES		

◆ K1

◆

◆

RoHS

◆

◆

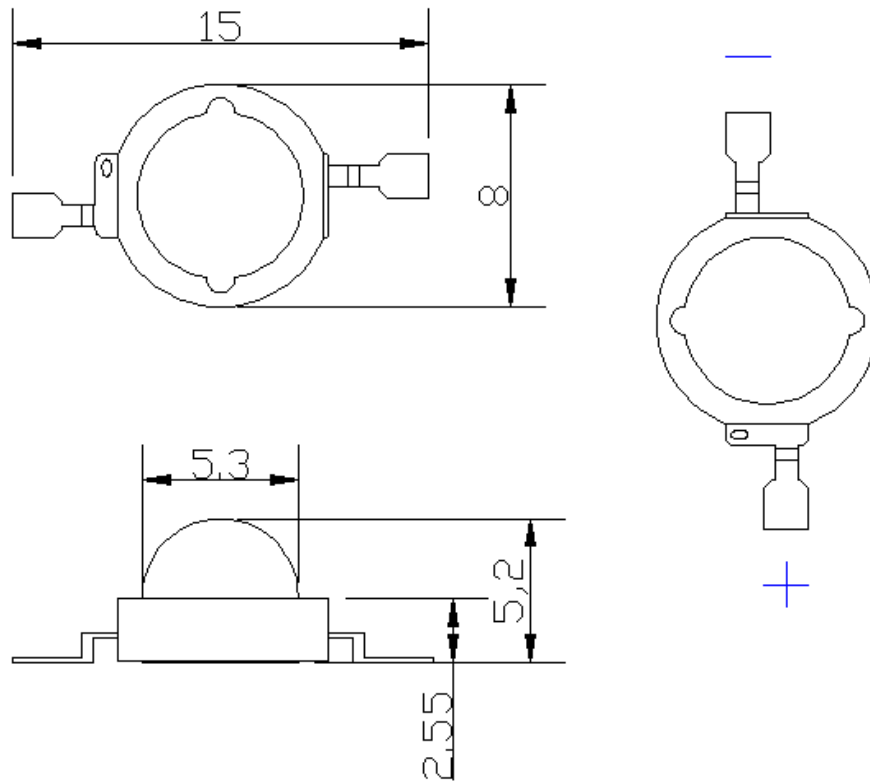

.X 0.1mm .XX 0.05mm

921NIRPC/D28-S	AlGaAs	Infrared	



	PD	1500	mW
	IFP	1200	mA
	IF	750	mA
	Topr	-25 to +80	
	Tstg	-25 to +100	
	Tsld	240 /10	

"! " !

	Symbol	Min.	Typ.	Max.	Unit	Test Condition
	Po	280	330	----	mw	IF=600mA
	2 "	----	120	----	Deg	
	p	840	855	865	nm	IF=600mA
		----	40	----	nm	IF=600mA
	VF	1.5	1.7	2.0	V	IF=600mA
	IR	----	----	10	A	VR=5V



■ 正向电压VS正向电流曲线

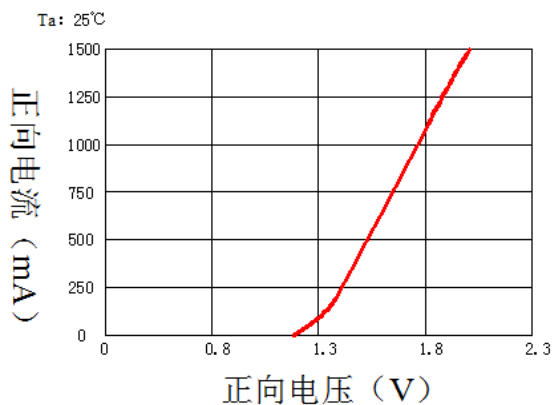

■ 正向电流VS相对辐射功率曲线

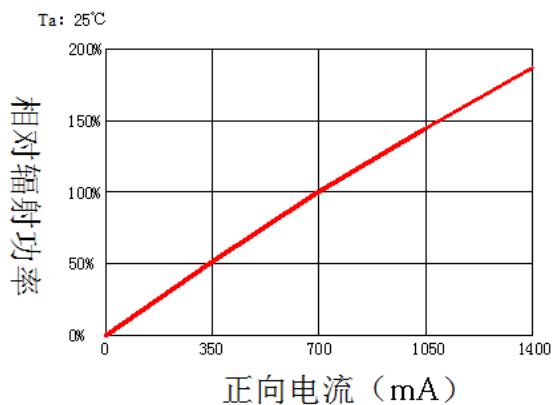

■ 结温VS相对辐射功率曲线

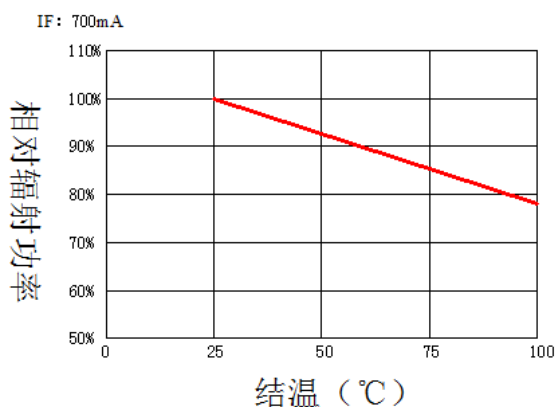

■ 结温VS正向电压曲线

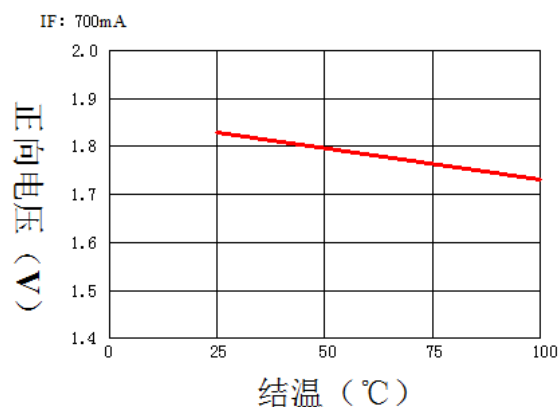

■ 波长VS相对光谱能量曲线

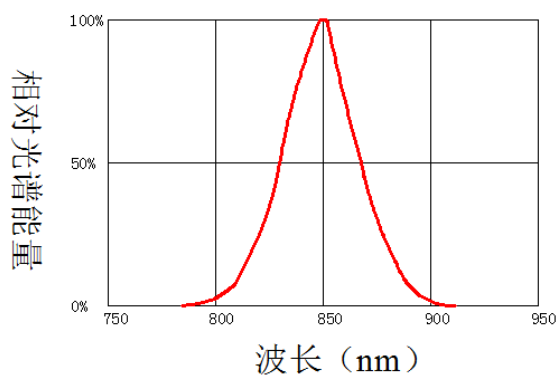

■ 相对辐射强度VS角度曲线

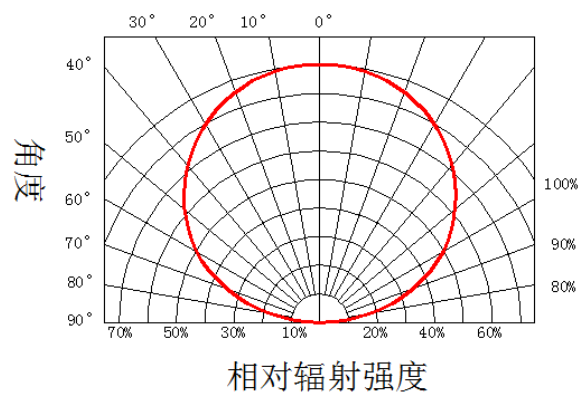

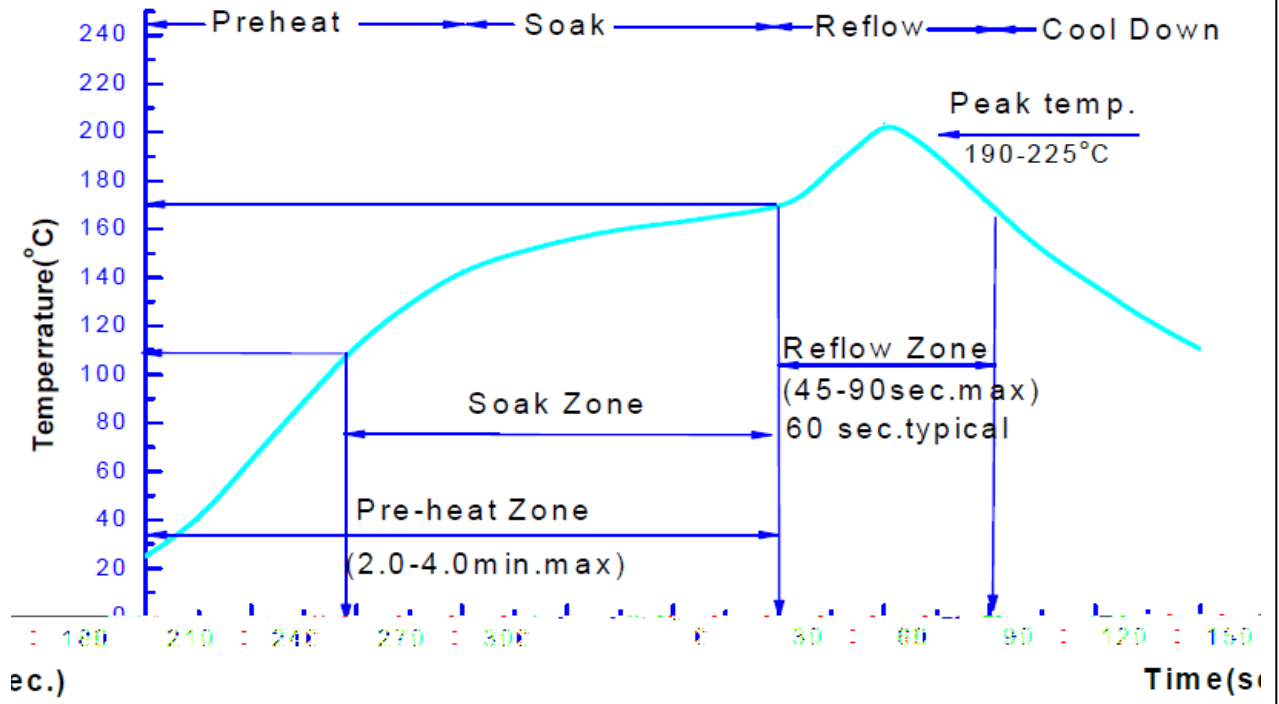

	" !
	! " !
)
	! " !
	"! !



” ! !)
 ! !
 % ” ” ! %
 ” LED
 LED LED
 LED

	30%	40%	50%	60%	70%	80%	90%
30 ℃	9	5	4	3	1	1	1
25 ℃	12	7	5	4	2	1	1
20 ℃	17	9	7	6	2	2	1

”
 % !
 ! 4 %
 ! 4

